

GN 317 Ratchet spanner

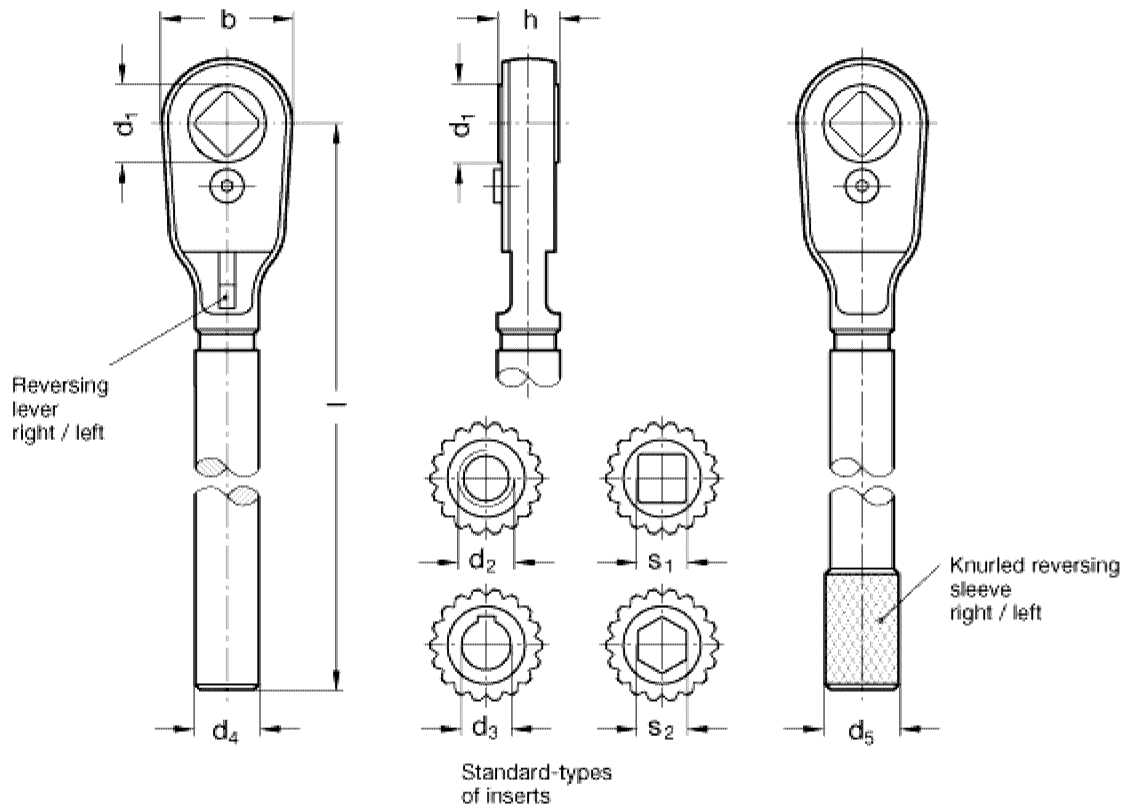

Type **A** reversal right / left, lever operated

Type **B** reversal right / left, knurled sleeve operated

| d1 | d26G | d3H7 | s1 | s2 | b | d4 | d5 | h | l | max. torque [Nm] | | | |
|-----------|--------------|--------------------|------------|------------|------------|-------------|---------------|----|-----|------------------|----|-----|-----|
| Ø Insert | Thread | Bore K with Keyway | Square V | Hexagon SK | | | | | | | | | |
| 12 | M 8 | - | V8 | - | 21 | 12 | 15 | 8 | 115 | 40 | | | |
| 17 | M 10 | M 12 | K10 | K12 | V10 | - | •SK 12 | 29 | 15 | 19 | 11 | 155 | 100 |
| 22 | •M 14 | M 16 | K14 | K16 | V12 | V14 | •SK 14 | 37 | 18 | 23 | 17 | 175 | 130 |
| 26 | M 20 | - | K18 | - | V17 | - | •SK 17 | 45 | 20 | 28 | 22 | 220 | 180 |
| 35 | M 24 | - | K22 | K24 | V19 | V22 | •SK 19 | 56 | 25 | 32 | 28 | 300 | 400 |
| 45 | - | - | K25 | - | V24 | •V27 | •SK 22 | 70 | 28 | 36 | 36 | 380 | 500 |

Specification

Steel
Housing blackened
Wearing parts hardened

Information

Ratchet spanners GN 317 are used for assembly and repair work. They are, however, also practical for fixed applications on any machinery and equipment. They are well designed of robust construction and simple to use.

The type with knurled sleeve (B) is used in such cases where the switch-over lever becomes inaccessible.

How to order

Ratchet spanner

GN 317-26-V17 A

Code no. **317**
d1 **26**
d2, d3, s1, **V17**
s2
Type

The sizes and types marked thus • are as a rule not available from stock